



Application

It is widely used for

- Pressure boosting for domestic water supply
- Floor heating system
- Solar pumping system

Pump

- Automatic pressure boosting
- Anti-rust cast iron pump body
- Noryl impeller with heat resistance up to 150°C
- 99% alumina ceramic shaft
- Liquid temperature: 2°C - 60°C

Motor

- Insulation class: H
- Protection class: IP42
- 99% alumina ceramic bearing

MODEL	VOLTAGE/FREQUENCY	POWER (W)	Max. Flow (l/min)	Max. Head (m)	Inlet/Outlet (mm)	Pipe Size (inch)
LRP15-90A/160	110~120V/60Hz	123	25	9	Ø15	1

Materials Table

No.	Part	Material
1	Rotor	
2	Thrust bearing adjusting mat	Noryl
3	Thrust bearing rubber mat	Silicon rubber
4	Thrust bearing	Graphite
5	Front bearing	Alumina
6	Pump support cover	Stainless steel
7	Check ball	Silicon rubber
8	Impeller	PPO
9	Pump body	Cast iron/Bronze
10	Pump body insert	Stainless steel
11	Body gasket	
12	Rear bearing	HT200
13	Can brg asm	Stainless steel
14	Can brg asm seal	Silicon rubber
15	Stator cover(front)	PA66
16	Motor stator with winding	
17	Stator cover(back)	PA66
18	Housing	ADC12
19	Cable outlet nut	ABS
20	Button	ABS
21	Terminal box	PA6
22	Regulation switch	
23	Capacitor	
24	Terminal cover	ABS
25	Flow switch assembly	

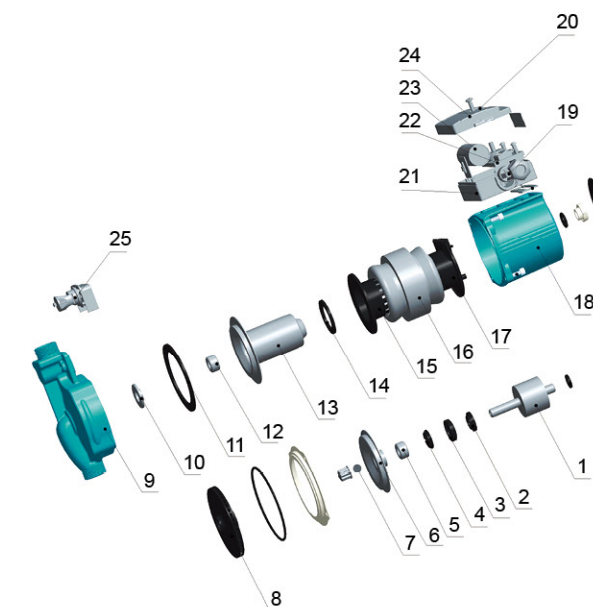

Dimension Drawing

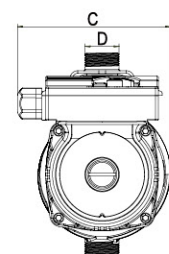
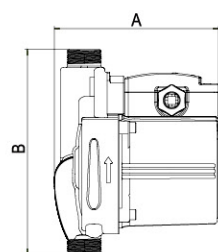

Identification Codes

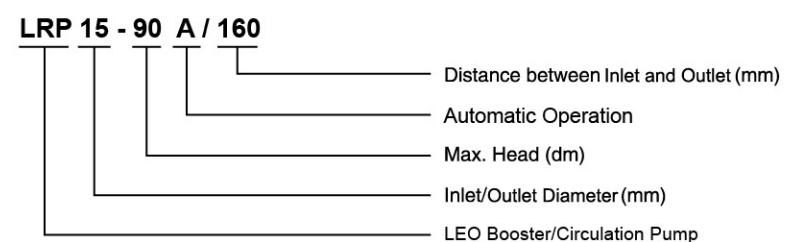

MODEL	A (mm)	B (mm)	C (mm)	D
LRP15-90A/160	129	160	120	G ^{3/4}

